

Warning Signs

Installation and Operation Manual

Man-1139 Issue 02 April 2011



Index	Page
Overview	3
Installation.....	3
Cabling	4
Inputs	5
Connections for inputs	7
Connections for Outputs	7
External sounder	8
Configuration switch.....	9
Technical specification	9

Overview

The K27000 illuminated warning signs provide a clear, visual and audible warning for a variety of applications. Standard units are available to provide warning of a fire alarm or extinguishant release but the display may be customised to show any text on several coloured backgrounds.

Warning signs have two levels of operation in which the top and bottom halves of the sign may be split to show an initial warning and then additional text for a reinforced warning if required.

The two levels may be activated either by a common and two switched signals or by application of a DC supply which reverses polarity to signal level 2.

The signs are suitable for Fire, Extinguishing, Security and any other type of alarm system. The signs have a wide operating voltage from 15 to 30 Volts DC making them suitable for a wide range of applications.

The use of high brightness, white LED indicators minimises power consumption and maximises reliability.

Installation

Remove the front plate and use the back box as a template to mark the three fixings in the required position on the mounting surface.

The back box must be fixed level and in all three mounting positions on a flat surface using bolts or screws with a minimum diameter of 4mm.

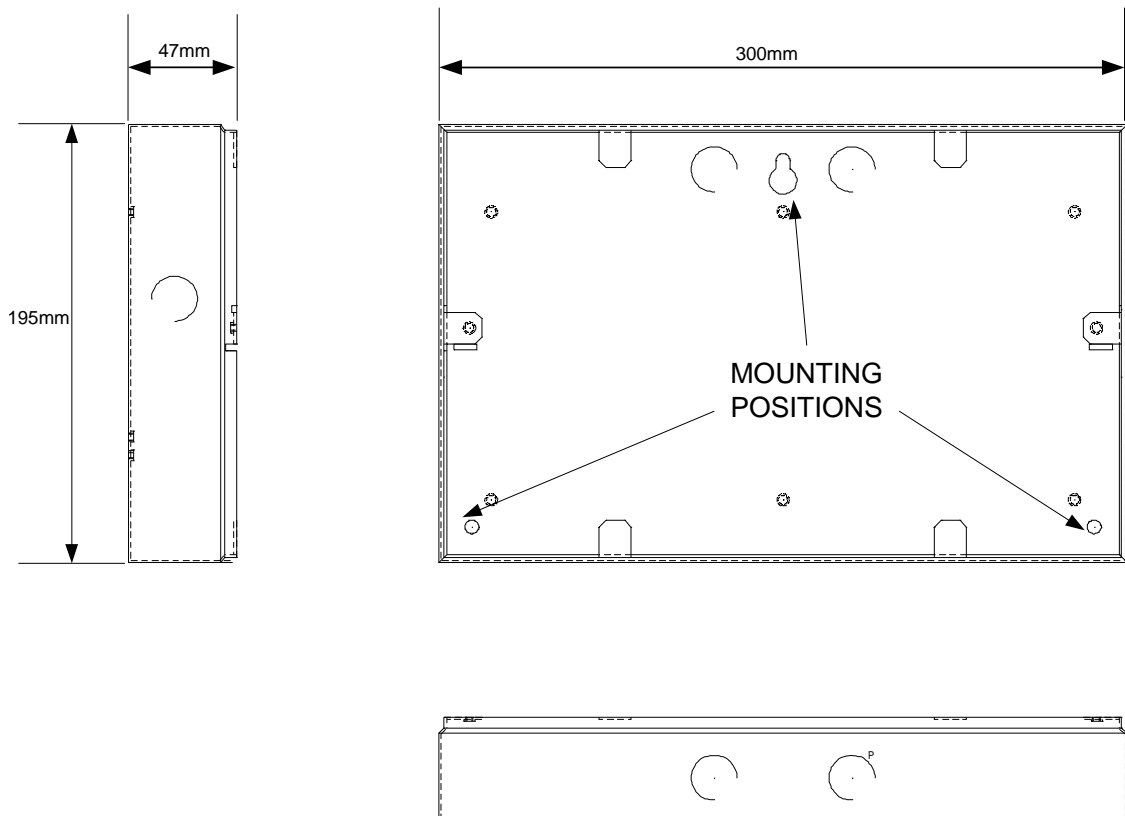

Cabling

The back box has two 20mm knockouts in the top, bottom and back and one 20mm knockout in each side.

Knockouts can be removed by sharply tapping them and when loose, pushing them back and forth until they break off.

The maximum size of cable that the terminals will accommodate is 2.5mm².

Cables should be connected using suitable cable glands and should have tails of sufficient length to reach the required terminals.

Do not install cables across the front surface of the circuit board as this will impair the light output of the unit.

CORRECT WIRING

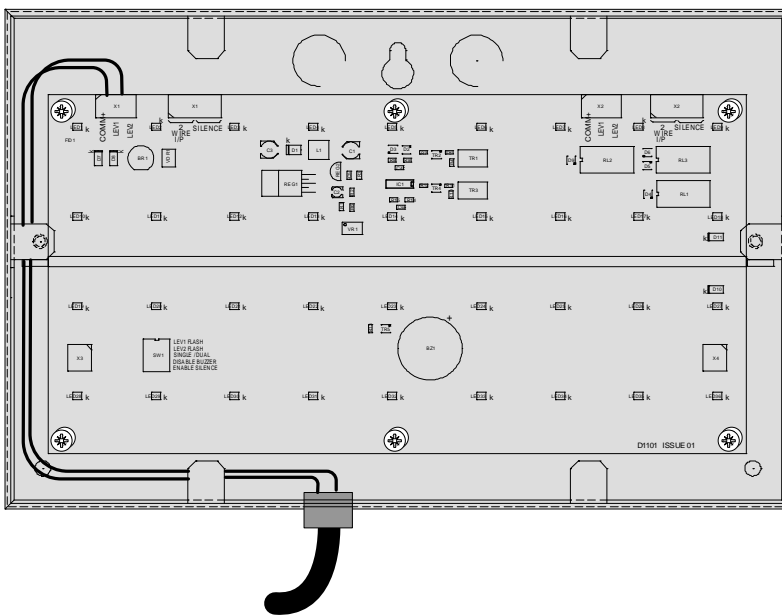

INCORRECT WIRING

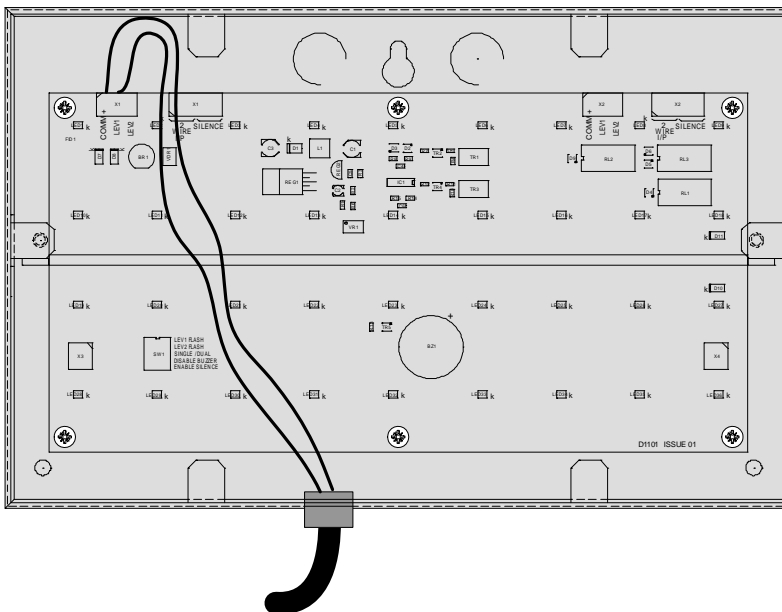

Inputs

The warning sign can be configured to illuminate in a variety of ways.

Jumper J1 in position A

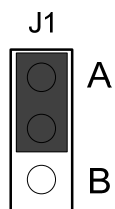

With J1 in this position it is possible to illuminate each half of the sign independently.

Connecting the + supply to the COMM+ terminal and the – supply to the LEV1 terminal will illuminate the lower half of the sign as shown below.

Connecting the + supply to the COMM+ terminal and the – supply to the LEV2 terminal will illuminate the upper half of the sign as shown below.

Connecting + and – to the 2 WIRE I/P will illuminate the upper half of the sign as shown below

Connecting - and + to the 2 WIRE I/P will illuminate the lower half of the sign as shown below.



Level 2 input operated



Level 1 input operated

Jumper J1 in position B

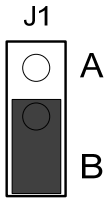

With J1 in this position it is possible to illuminate either the whole sign or just the upper half of the sign.

Connecting the + supply to the COMM+ terminal and the – supply to the LEV1 terminal will illuminate the whole sign as shown below.

Connecting the + supply to the COMM+ terminal and the – supply to the LEV2 terminal will illuminate the upper half of the sign as shown below.

Connecting + and – to the 2 WIRE I/P will illuminate the upper half of the sign as shown below

Connecting - and + to the 2 WIRE I/P will illuminate the whole sign as shown below.



Level 2 input operated



Level 1 input operated

Connections for inputs

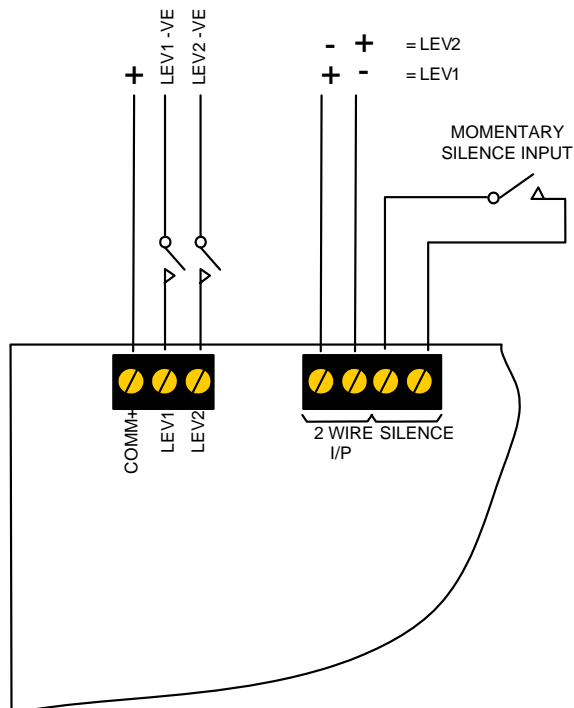

Connect 15 to 30 Volt DC supply as shown.

If the internal buzzer is enabled then it can be silenced by an external, normally open volt free contact momentarily connected to the terminals marked SILENCE.

Connections for Outputs

The terminals for activating the warning sign are duplicated on the right hand side of the circuit board for the connection of further signs on the same circuit if required.

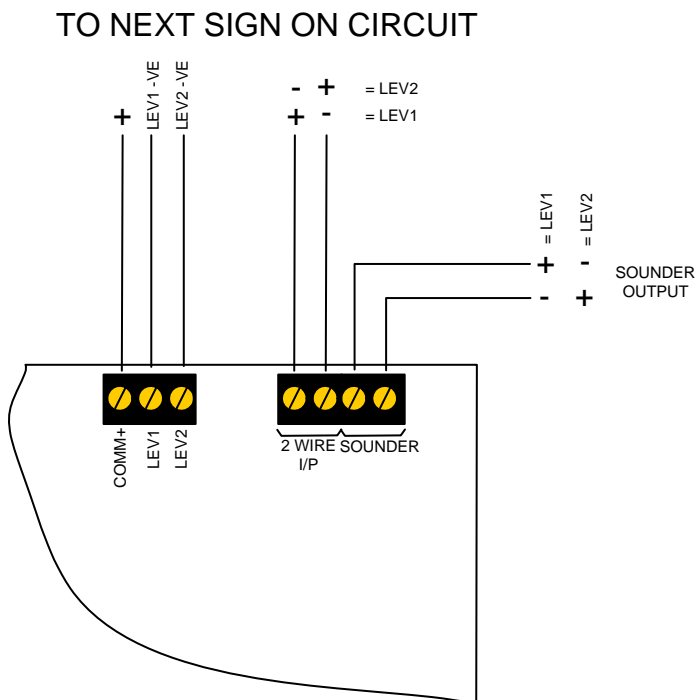

External sounder

There are an additional two terminals which can be used for connecting to an external sounder.

The sounder can be a conventional, polarised type or a two tone sounder with a voltage reversing input to signal the two different levels of activation. This sounder output will also silence when the SILENCE input is operated.

The voltage that appears at the sounder output will be the same voltage as the input voltage used to activate the warning sign. Sounder current will be sourced by the input that activates the warning sign so this must be taken into consideration when calculating the rating of the circuit that supplies power for the warning sign.

CONNECTION TO 2 WIRE BIPOLAR SOUNDER FOR DIFFERENT SOUNDS ON LEVEL 1 AND LEVEL 2

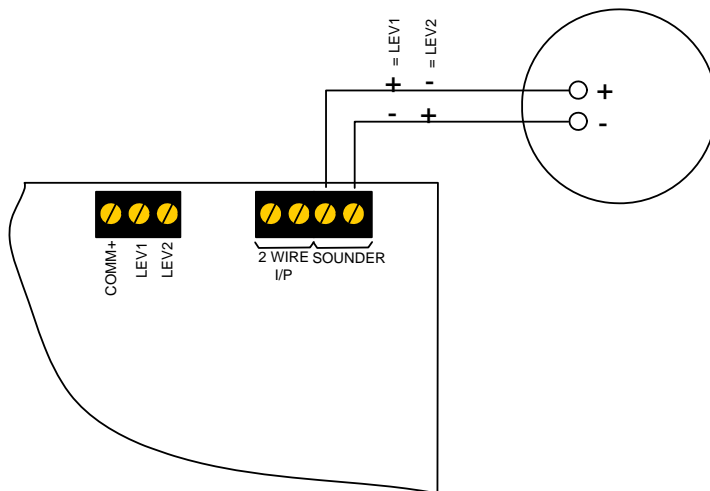

CONNECTION TO 2 WIRE POLARISED SOUNDER WHICH SOUNDS ON LEVEL 2 ONLY

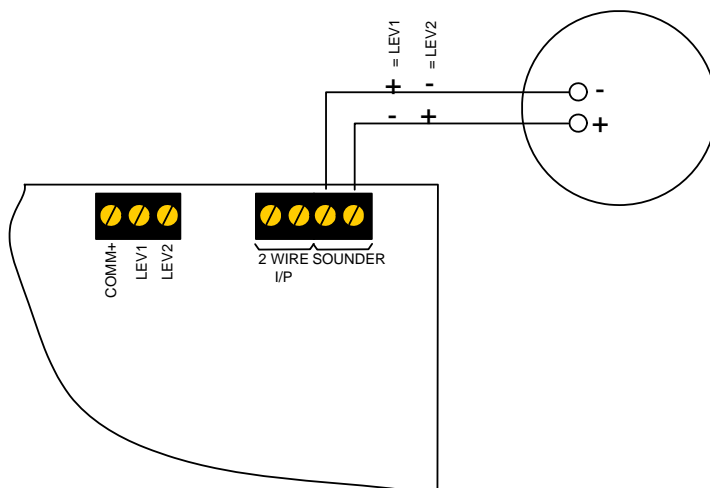

Configuration switch

The configuration switch allows the sign to be configured to suit the application and provides the facility to choose whether the top and bottom halves are flashing or steady when activated, whether the unit is a single or dual level sign, whether the buzzer will sound upon activation and whether the silence input is enabled or disabled.

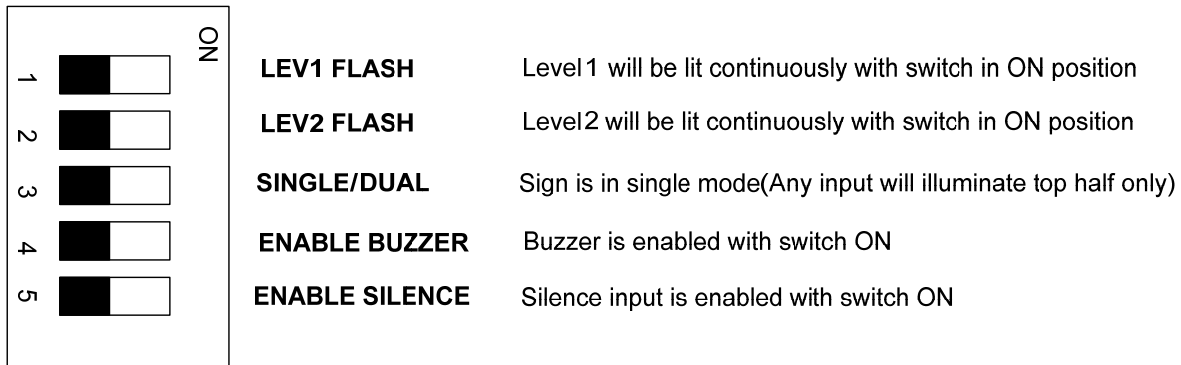

Technical specification

Size - 300mm X 195mm X 50mm

Construction – 1.2mm filly welded sheet steel

Finish – Epoxy powder coated

Colour (lid and box) – BS00 A 05 grey fine texture

Operating voltage – 15V to 30V DC

Current consumption – 130 milliamps at 24V DC (both halves of sign lit and buzzer sounding)

Operating temperature - -5 to + 50 degrees C

Operating humidity – To 95% non-condensing

Sounder output – Maximum current limited by circuit that supplies the warning sign with power.