

# Syncro

## Multi Loop Analogue Addressable Fire Control Panel

### 8 Way Relay Board Manual

Man-1074 Issue 03 June 2013

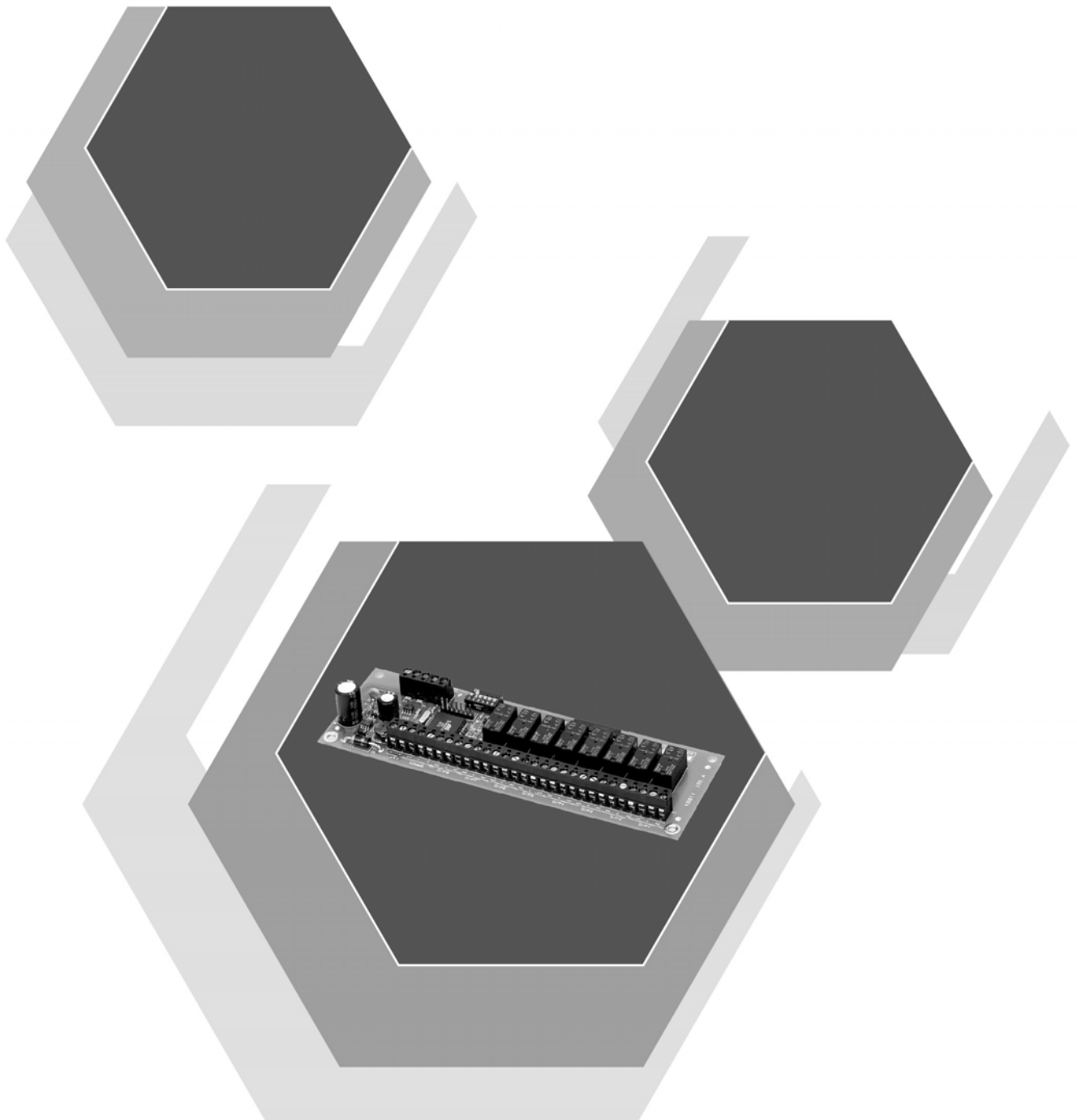

# Index

# Page

1. General .....	3
2. Relay outputs .....	3
3. Addressing .....	4
4. Terminating .....	4
5. Power connections .....	4
6. Power consumption – battery standby .....	5
7. Data connections .....	5
8. Indications .....	6
9. Specifications .....	6

# 1. General

To further enhance the versatility of the Syncro fire alarm system, additional relay output capability can be added using Syncro relay boards.

These boards have 8 voltage free changeover relay contacts, each of which can be individually programmed.

Up to 32 of these boards can be connected to the dedicated RS485 communications bus in the control panel giving the capability of up to 256 additional relay outputs.

The S547 relay boards may be mixed on the RS485 bus with S560 16 channel I/O boards, S545 Conventional detection boards or S546 6 way sounder boards to provide a very flexible system of I/O to satisfy almost any requirement.

All outputs are configurable in the same way as devices connected to the loops and all may be acted upon by cause and effect logic.

These boards are typically used in applications which require more than the four standard relay outputs such as signaling to other systems or plant control.

Standard Syncro control panels contain fixings for one Sounder, Relay, Conventional detection or I/O board and can easily be connected using four small signal wires to the power and comms bus within the panel.

# 2. Relay outputs

The board has 8 general purpose relay outputs for local control where a low voltage relay contact is required. Each output is a voltage free changeover contact with a maximum rating of 1 Amp and 30 Volts DC.

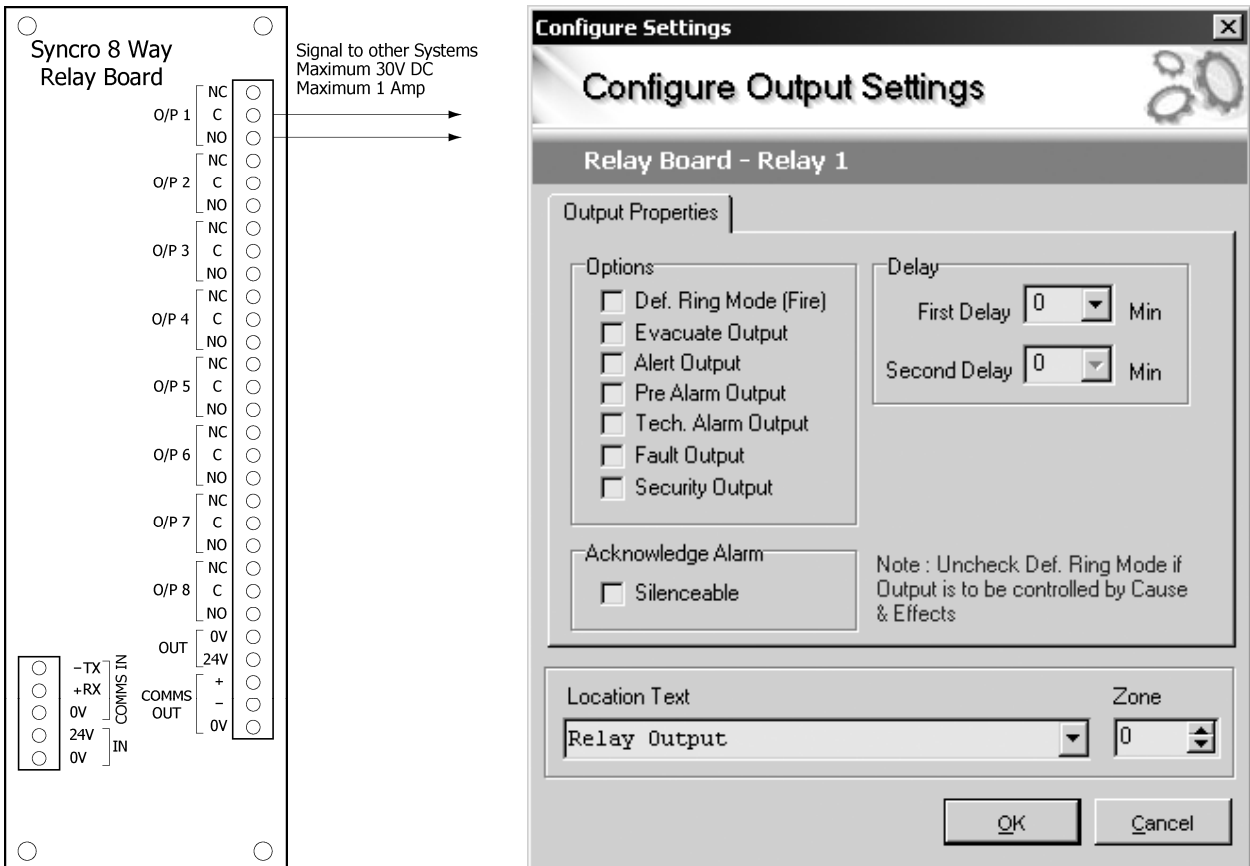

Outputs can be configured to operate upon any event type with the Loop Explorer configuration programme.

### 3. Addressing

Up to 32 sounder, relay or I/O boards may be connected to a control panel and in order for the panel to recognise them individually; each board must be allocated an address.

This is done via a DIL switch (as is used on many field devices) and setting a binary number. Care should be taken where more than one board is used to give each board a unique address setting.

Some example address number settings are shown below.

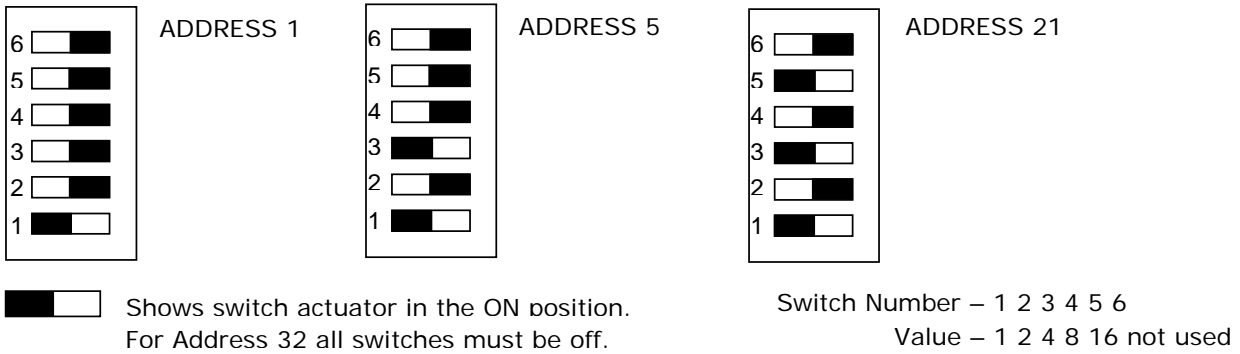

### 4. Terminating

The last board connected to the RS485 communications bus, must have the terminating jumper fitted at position J2 as shown here.

This jumper should remain fitted even if only one board is connected to the bus.

Remove and discard the jumper if the board is not the last on the line.

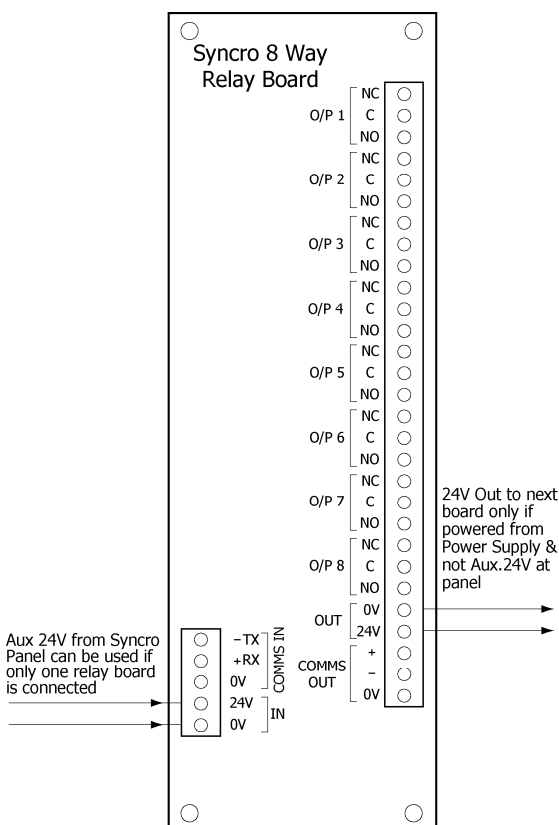
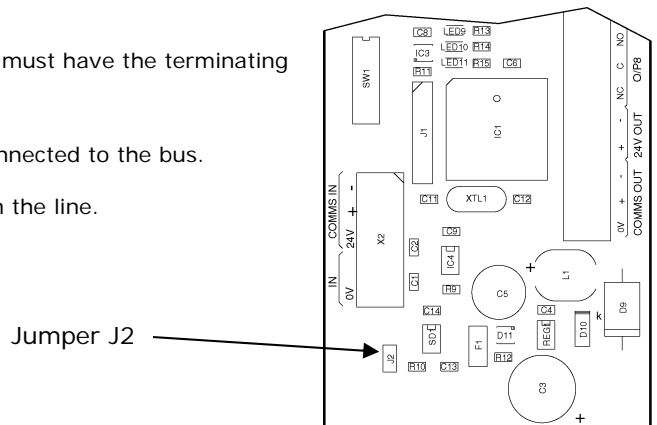

### 5. Power connections

The relay board requires a nominal 24V DC supply. This can be between 21 and 30 volts DC, a voltage range, which suits battery-backed systems.

The total power consumption of the board with all relays operated is less than 250 mA and the Aux 24V supply in the control panel is capable of supplying one board.

If more than one relay board is to be connected to a standard control panel the supply for the boards should be taken directly from the + and - connections on the panel power supply

The rating of the power supply must be taken into consideration if a number of relay boards are to be connected.

Connections are provided for both incoming and outgoing power as shown below.

## 6. Power consumption – battery standby

The effect of the power consumption of relay boards must be considered when calculating battery standby.

Each board has a quiescent current consumption of 10 mA which will require  $(24 \times 0.01A) + 25\% = 0.3Ah$  of extra battery capacity per 24 hour standby period.

The relays must be able to operate for half an hour at the end of the standby period so additional capacity of  $(0.5 \times 0.25) + 25\%$  in Ah (0.15) should be added to the required battery capacity to cover this.

## 7. Data connections

The panel communicates with relay boards using a 2 wire RS485 data bus. This bus is available on the main termination board in the control panel.

Connections to relay boards within the control panel can be made with small gauge equipment wire. Connections to boards mounted outside of the control panel should be made using a suitable RS485 data communications cable such as Belden 9271.

Connections are provided for both incoming and outgoing data as shown below.

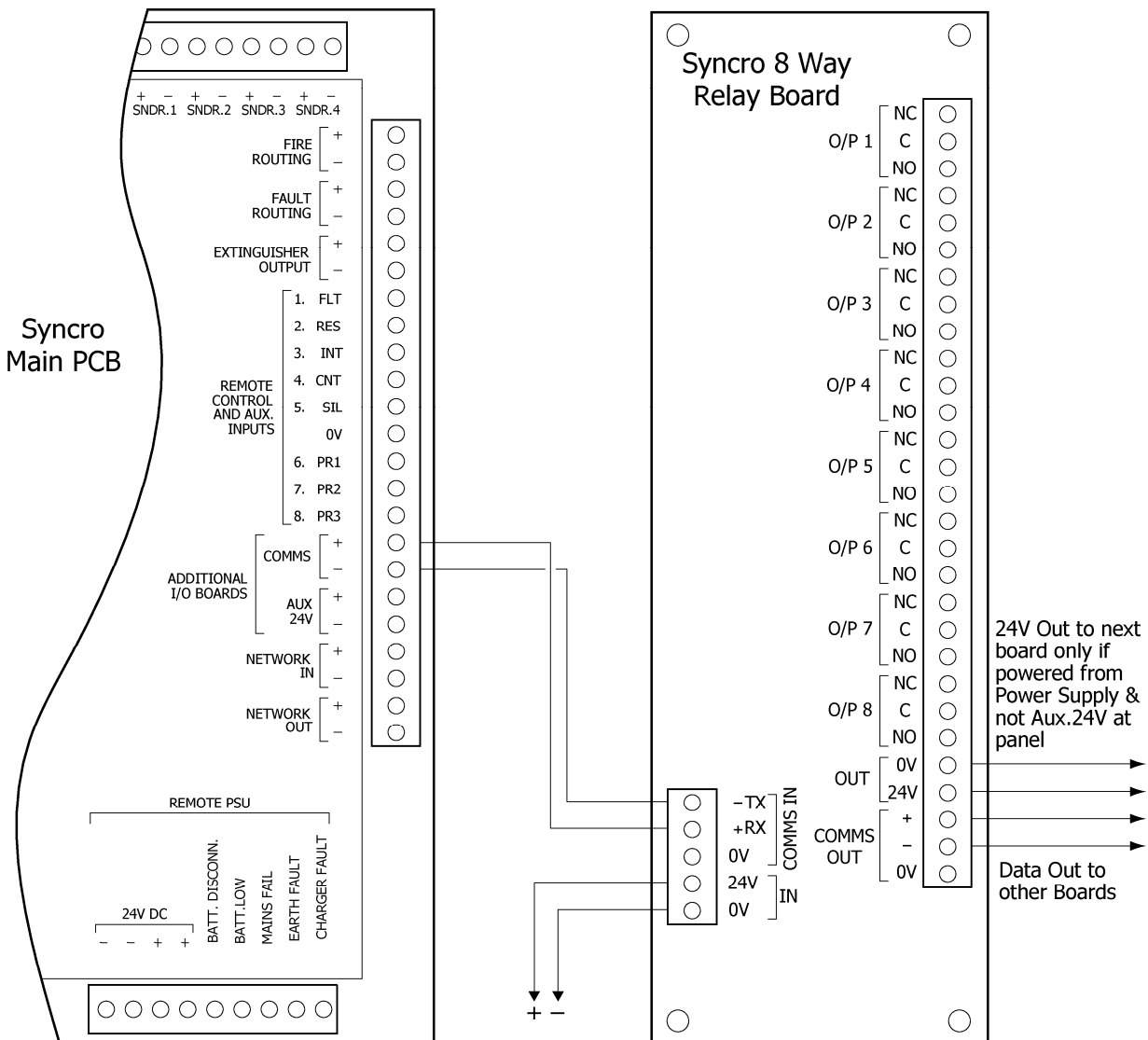

## 8. Indications

LED indicators on the relay board give some simple diagnostic information and show that the boards are communicating with the control panel.

The red LED (LED 10) is used to show serial data communication is being received from the control panel.

This LED should be flickering more or less continuously when the board is operating normally.

If this LED is not lit, then the board is not receiving data from the control panel and the comms connection should be checked.

If this LED is permanently lit, then it is likely that data is being received but that it is being corrupted.

In this case the quality of the comms connection should be checked for interference from mains or other noise generating sources.

The yellow LED (LED11) will flicker briefly every few seconds when the board responds to the main panel.

If this LED does not flicker then it is not responding to the control panel and the comms connection should be checked.

These simple indications are not designed to provide detailed diagnostic help but should assist in establishing whether boards are communicating correctly with the control panel.

Red LEDs are provided for each of the 8 relay outputs to indicate operation of the relay.

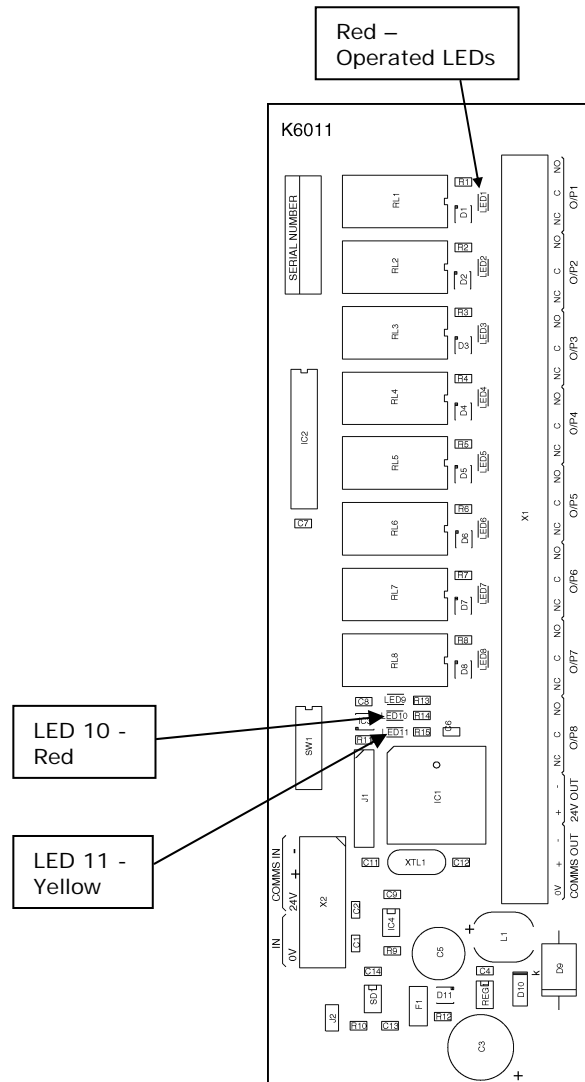

## 9. Specifications

Part number – S547

Supply voltage range – 21 to 30 Volts DC

Quiescent current consumption – 10 milliamps

Maximum current consumption 250 milliamps

Output contact rating – 30 V DC 1 Amp

Communications – RS485 two wire

Maximum distance from control panel – 1200 metres (subject to correct type of cable)

PCB size – 190mm X 61mm

Fixing centres – 51.5mm X 180mm

Cable capacity – 2.5mm<sup>2</sup> per terminal

Operating temperature - -5° to +50° Celsius

Operating humidity - <95% non-condensing

Control panel compatibility – Compatible with control panels fitted with software versions V3.4 upwards